

EXECUTIVE DESIGN SPECIFICATIONS - MANUAL SYSTEM WITH STANDARD SIDE TRACK (V2A)

FOR ILLUSTRATION PURPOSES - NOT DRAWN TO SCALE
(External Assembled View)

Parts Spec

- A Housing Assembly:
(5-1/2"W x 5-1/2"H)
- B #8 x 1" Corrosion Resistant Fastener (Color Matched)
3 Fasteners per End Cap
- C PVC Coated Fiberglass Mesh
or other - see Mesh Specifications
- D Standard Side Track (V2A) c/w Cover (1-3/4" W x 1-17/32" D)
- E #8 or #10 Corrosion Resistant Fastener
Type and length of screws may
vary depending on type of mounting surface
- F Slide Bar c/w Probe Assembly
- G Bottom Seal - 4" Shown (Other Options Available)

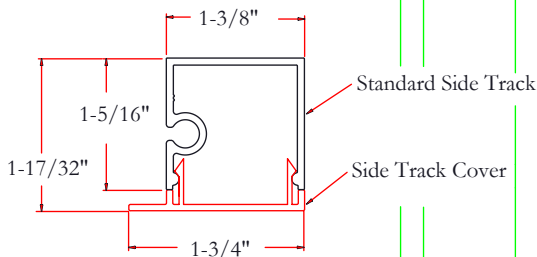

CROSS SECTIONAL VIEW
OF THE
STANDARD SIDE TRACK (V2A)

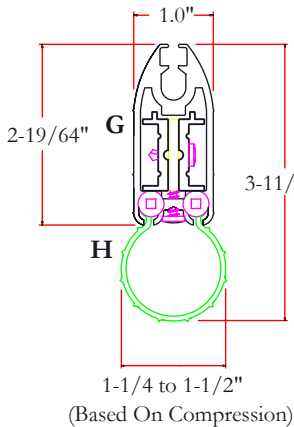

CROSS SECTIONAL VIEW
OF THE
SLIDE BAR AND
4" BOTTOM SEAL

(Overall Height Of The
Slide Bar And Bottom
Seal In A "Non-Compressed
State")

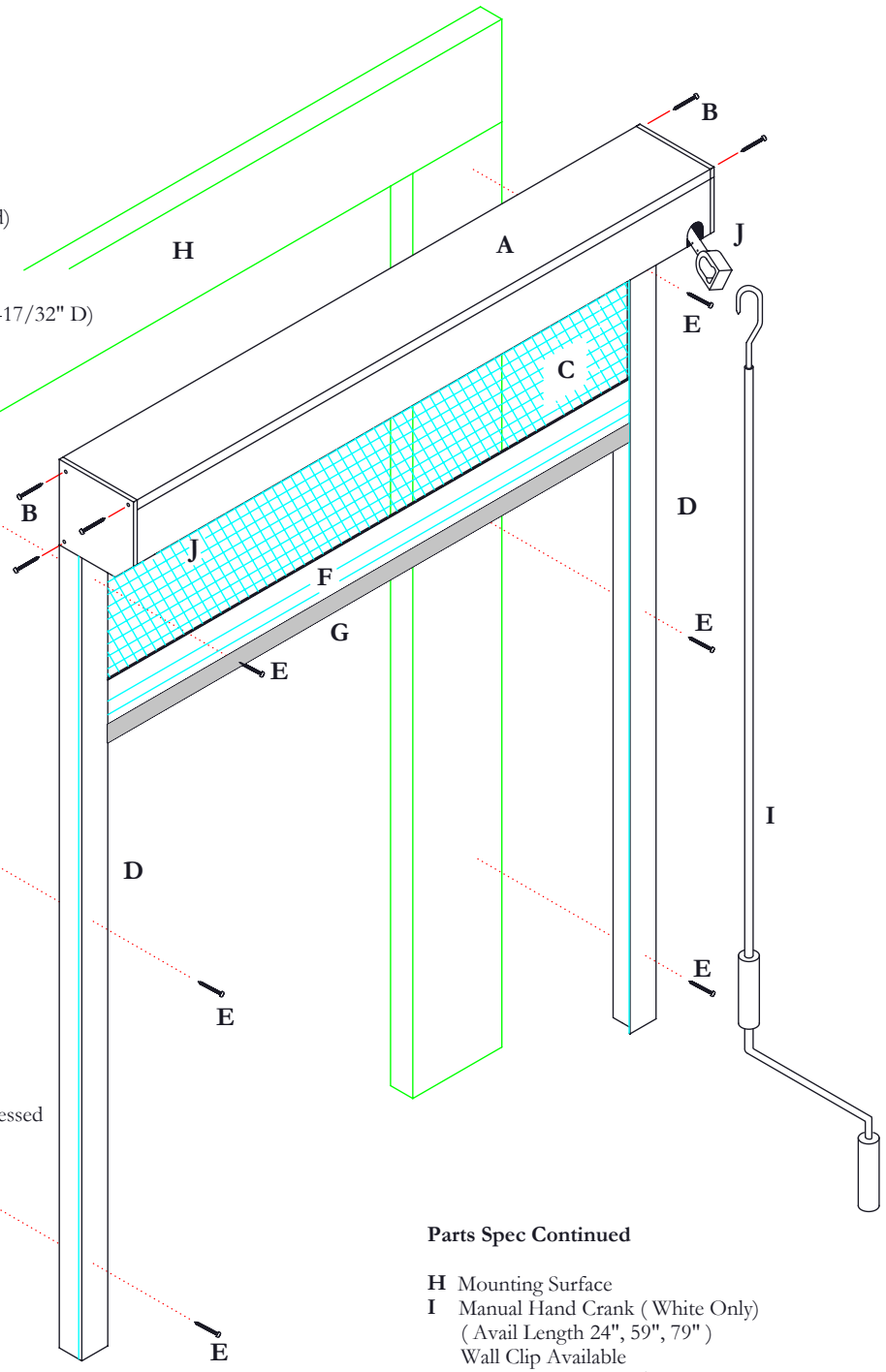

Parts Spec Continued

- H Mounting Surface
- I Manual Hand Crank (White Only)
(Avail Length 24", 59", 79")
Wall Clip Available
- J Eye and Shaft for 11/1 Manual Gear
Right Hand Mount Shown (Standard)
Left Hand Mount Option Available